

Watson's Streetworks has an extensive line of street rod and custom car and truck parts with one of the largest selections of billet interior trim and electrical accessories.

Check us out on the web at www.watsons-streetworks.com

4 Bud Way, Suite 3, Nashua, NH 03063 866-859-0513
 Tech@Watsons-Streetworks.com

GT2 Power Window Switch #10231 Without Dividers

Power Window Switches with Short Rockers to match our GT4D Switches. Gives you a double for the driver, and a single for your passenger. Comes with Polarity Reversing Module. No Other relays needed.

DISCONNECT MAIN POWER AT THE BATTERY
BEFORE DOING ANY WIRING!

- 1. Determine the Location** for the switches in your door or console. Switches mount on top of panel. This requires that you wire switches as a last step. Make sure you leave ample wire for panel removal. See sketches.
- 2. Cut Switch Holes** using the template/ dimensions carefully mark and cut holes.
- 3. Do the Wiring.** Follow Diagram On Page 2.
- 4. Reconnect the main power and test your wiring**

Doing electrical work, but you just aren't quite sure of yourself? Pick up a copy of our Basic Automotive Electricity Book. This fact filled book walks you through electricity from the basics to a complete automotive circuit diagram. And at just \$7.95 it's better than aspirin at solving electrical headaches!

This single switch represents one switch of the two switches on the driver Switch Master Panel.

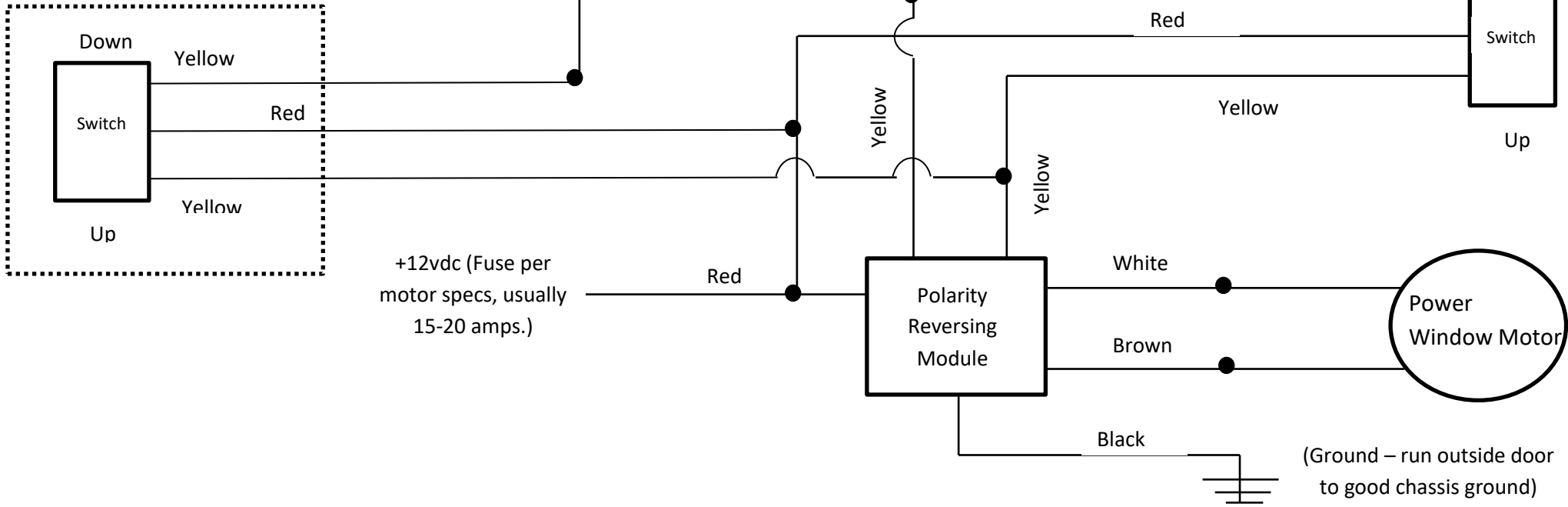

Driver Window Wiring Diagram

