

1. Determine the Location for the switches in your door panel or console. There are two ways that the switch, frame and your panel can come together – (1) with the switch and frame both outside the panel, or (2) with the switch inside the panel (3/16" max. panel thickness) and the frame outside the panel. Case (1) requires that you wire the switches as a last step as the panel ins installed. Case (2) allows you to wire everything, then install the switch, panel and frame when the panel is installed. For either case, the switch and frame will be attached to the panel, so leave ample wire to allow panel removal. See Sketches Below.

Case 1

Case 2

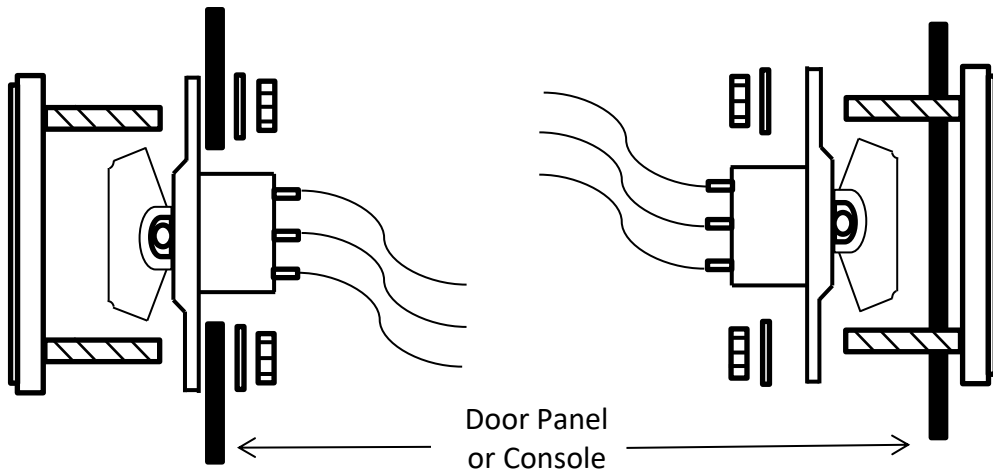

2. Cut Switch Holes using the template/ dimensions **carefully** mark and cut holes.

3. Do the Wiring. These are SPDT (single pole, double throw) switches. If the red wire is connected to +12vdc, the yellow or gray wires will be energized +12vdc alternately as the switch is pushed one way or the other. Gray wires indicate the switch is a latching on/off/on switch.

4. Reconnect the main power and test your wiring. For switches not oriented correctly, reverse either the yellow wire leads or the orientation of the switch in the panel.

Check us out on the web at www.watsons-streetworks.com

**4 Switch Oval Custom
Dimpled Switch Panel**

#L39BO4X

(Mom. On) – OFF – (Mom. On) or ON/OFF/ON switches (non-illuminated). 4 Billet switches and rectangular frame with lead wires. 5 amp **MAXIMUM** load. Additional relays may be needed for your application.

DISCONNECT MAIN POWER AT THE BATTERY
BEFORE DOING ANY WIRING!

Switch Panel Template

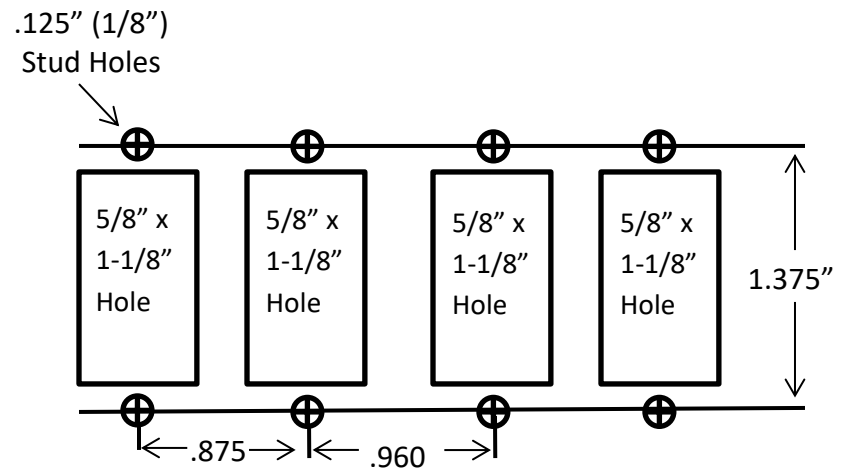

Doing electrical work, but you just aren't quite sure of yourself? Pick up a copy of our Basic Automotive Electricity Book. This fact filled book walks you through electricity from the basics to a complete automotive circuit diagram. And at just \$7.95 it's better than aspirin at solving electrical headaches!