

Watson's

DRIVE IT !

# StreetWorks

4 Bud Way, Ste 3, Nashua NH 03063

866.859.0513

Tech@watsons-streetworks.com



Thank you for buying a StreetWorks product. Be confident that it will provide the quality and performance that you demand for your car. *Please read and understand all installation instructions before beginning.* Planning and preparation will make the actual installation process easy and quick.

DISCONNECT ELECTRICAL POWER AT THE BATTERY BEFORE DOING ANY WIRING!

## BILLET ALUMINUM POWER WINDOW SWITCH

(1) "3-WIRE" SWITCH IN  
AN OVAL BILLET FRAME  
WITH POLARITY  
REVERSING MODULE

#L39BOS  
"Single Oval"

"3-WIRE" power window switch (non-illuminated). Single Billet switch and oval frame with lead wires and polarity reversing module. Adapts directly for use with (+) output remote controls - no additional relays needed.

**1. Determine the location** for the switch(es) in your door panel or console. There are two ways that the switch, frame and your panel can come together - (1) with the switch and frame both outside the panel, or (2) with the switch inside the panel (3/16" max. panel thickness) and the frame outside the panel. Case (1) requires that you wire the switch to the polarity reversing module as a last step as the panel is installed. Case (2) allows you to wire everything, then install the switch, panel and frame when the panel is installed. For either case, the switch and frame will be attached to the panel, so leave ample wire to allow panel removal. See sketches, below.

**Case (1)**

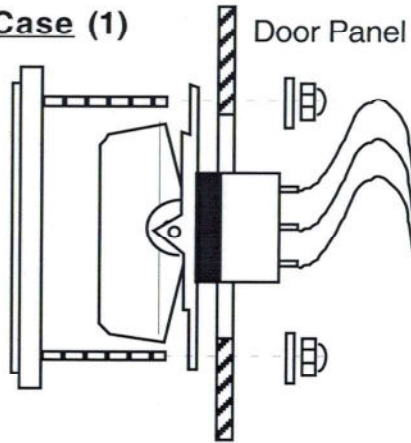

**Case (2)**

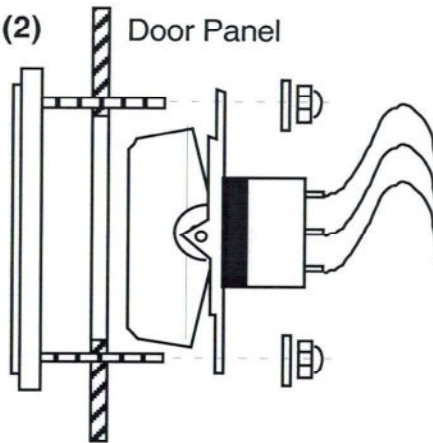

**Panel Hole  
Dimensions**

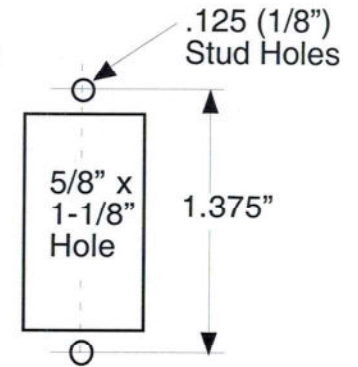

**2. Cut Switch Holes.** Using the template/dimensions, above, right, **carefully** mark and cut the holes.

**3. Do the Wiring.** The polarity reversing module (2 relay pack) can be located in the kick panel, under the dash or in the door. In the door makes for the least number of wires going in-and-out of the door (2 wires, not counting additional remote control or other switches), but the relay pack terminals must be protected from moisture. Always ground to a good chassis ground, not inside the door. Complete the wiring per the diagrams on the reverse side.

**4. Reconnect main power and test your window(s).** For switches not oriented correctly for UP/DOWN, reverse either the yellow wire leads or the switch orientation in the face plate.

Watson's

DRIVE IT !

# StreetWorks

4 Bud Way, Ste 3, Nashua NH 03063

866.859.0513

Tech@watsons-streetworks.com



## #L39BOS Instructions - Continued

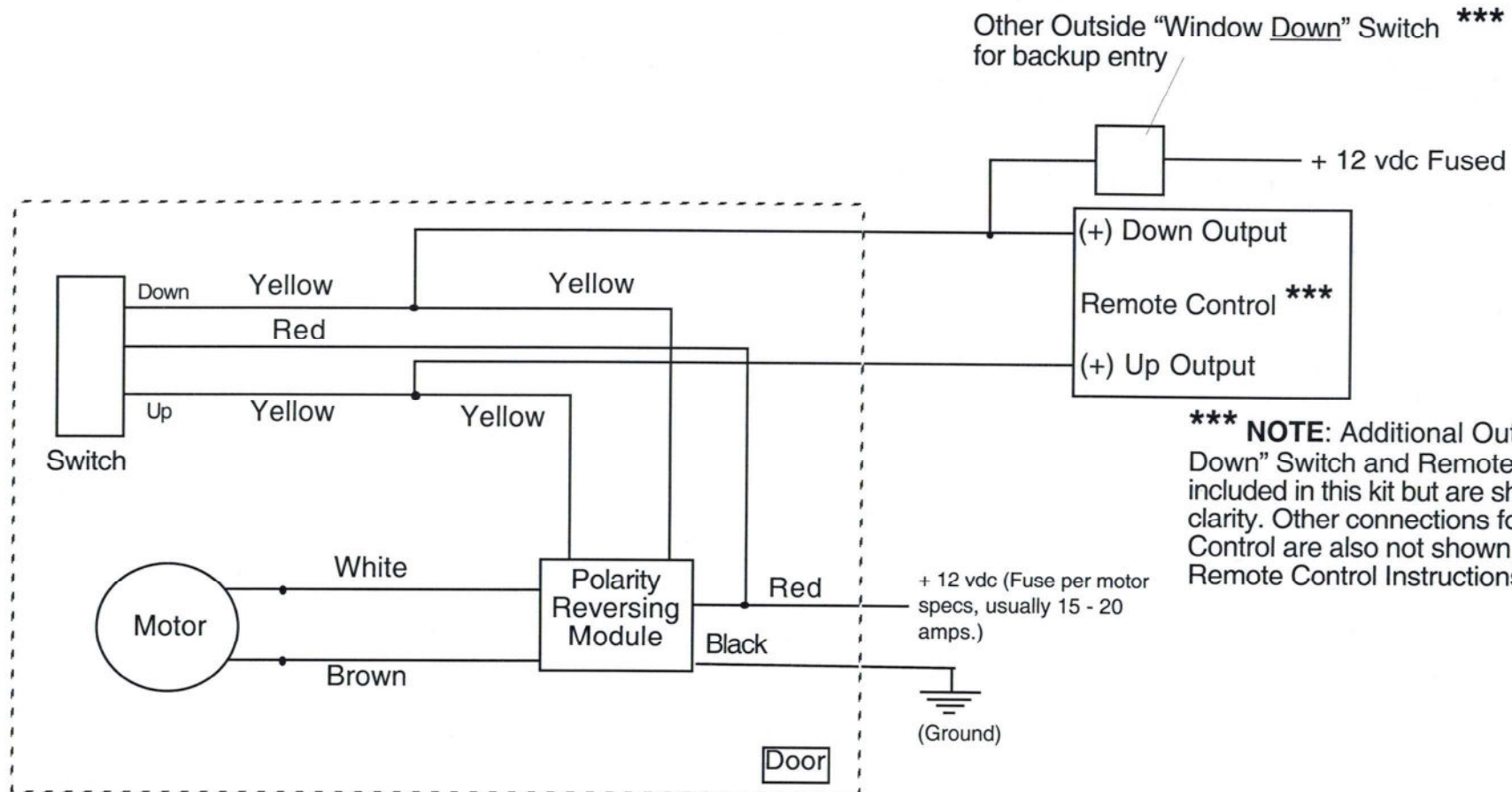

Other Outside "Window Down" Switch \*\*\*  
for backup entry

\*\*\* NOTE: Additional Outside "Window Down" Switch and Remote Control are not included in this kit but are shown for wiring clarity. Other connections for the Remote Control are also not shown, Refer to the Remote Control Instructions.