

Doing electrical work but you just aren't quite sure of yourself? Pick up a copy of our Basic Auto Electricity Book. This fact filled book walks you through electricity from the basics to a complete automotive circuit diagram. And at just \$7.95, it's better than aspirin at solving electrical headaches!

Ground Switched Circuit

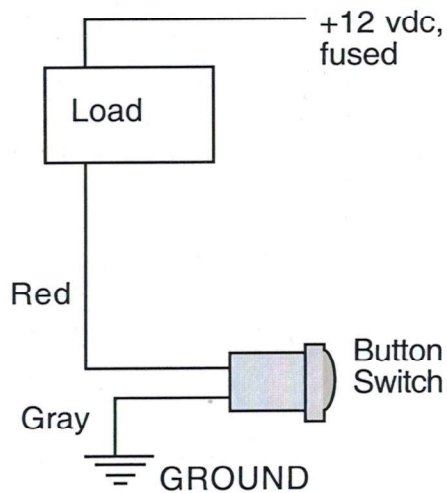

Positive Switched Circuit

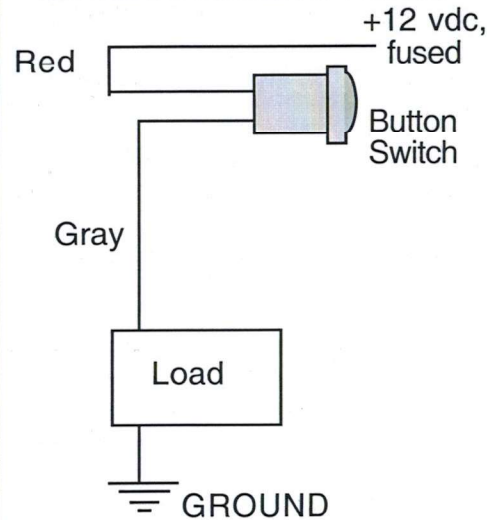

WATERPROOF BUTTON SWITCH

#L65BS

Waterproof button switch for use with door actuators or other momentary action systems. Switch is only 5/8" dia x 1/4" tall.

- Waterproof push button, momentary
- 5 amp momentary contact switching power (maximum)
- Switch mounts in a 1/2" diameter hole

Manufactured by Watson's StreetWorks Rod & Custom Products

Thank you for buying a StreetWorks product. Be confident that it will provide the quality and performance that you demand for your car. *Please read and understand all installation instructions before beginning.* Planning and preparation will make the entire process easy and quick. **DISCONNECT POWER AT THE BATTERY BEFORE DOING ANY WIRING!**

1. SWITCH MOUNTING: Determine a good location for the push button switch and mount by drilling a 1/2" diameter hole and secure with the hardware included. Wire the switch per one of the wiring diagrams shown. If the back side of the switch (solder joints) will also be in a wet environment, coat both solder connections with RTV or other non-conductive sealer. DO NOT exceed the 5 amp maximum for momentary use only.

NOTE: A relay **IS** required if the amperage draw of the load is equal to or greater than 5 amps.

2. RECONNECT main power and test your connections.

Watson's StreetWorks has an extensive line of street rod and custom car and truck parts with one of the largest selections of billet interior trim and electrical accessories. Check us out on the web at www.watsons-streetworks.com.

Thank you for buying our products !

Watson'sDRIVE IT !

StreetWorks

4 Bud Way, Ste 3, Nashua NH 03063
866.859.0513
Tech@watsons-streetworks.com

