

SINGLE-TO-DOUBLE
JEN-E LIGHT KIT

#L-JE01

This kit converts the smaller, single filament JEN-E light to work like a double filament bulb. It is designed specifically for use with that light and is not intended to be used with any other light.

Thank you for buying a StreetWorks product. Be confident that it will provide the quality and performance that you demand for your car. *Please read and understand all installation instructions before beginning.* Planning and preparation will make the actual installation process easy and quick.

DISCONNECT ELECTRICAL POWER AT THE BATTERY
BEFORE DOING ANY WIRING!

Connect the black wire to the JEN-E light, the red wire is the feed for the turn signal (full brightness), the gray wire is the feed for the park light (reduced brightness). Our unit may be wired in anyplace between the light switches (under the dash) and the light itself.

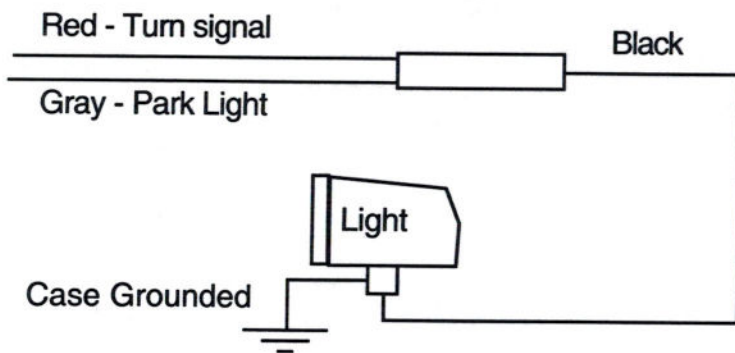

SINGLE-TO-DOUBLE
JEN-E LIGHT KIT

#L-JE01

This kit converts the smaller, single filament JEN-E light to work like a double filament bulb. It is designed specifically for use with that light and is not intended to be used with any other light.

Thank you for buying a StreetWorks product. Be confident that it will provide the quality and performance that you demand for your car. *Please read and understand all installation instructions before beginning.* Planning and preparation will make the actual installation process easy and quick.

DISCONNECT ELECTRICAL POWER AT THE BATTERY
BEFORE DOING ANY WIRING!

Connect the black wire to the JEN-E light, the red wire is the feed for the turn signal (full brightness), the gray wire is the feed for the park light (reduced brightness). Our unit may be wired in anyplace between the light switches (under the dash) and the light itself.

