



StreetWorks

4 Bud Way, Suite 3, Nashua, NH 03063 866-859-0513
Tech@Watsons-Streetworks.com

Thank you for buying a StreetWorks product. Be confident that it will provide the quality and performance that you demand for your car. *Please read and understand all installation instructions before beginning.* Planning and preparation will make the actual installation process easy and quick.

Backup Monitor and License Plate Camera

IT-MON-TH

Beautiful billet monitor backup camera, displays when you put your car in reverse. Camera bracket is easily mounted under your license plate, then all you see is the slim line camera coming over the plate. Over 15 feet of cable, and simple connection. Trigger comes from your backup light power.

DISCONNECT BATTERY BEFORE WIRING

1. Determine where you want to mount the monitor(See diagram for cutout.) Camera installation. Establish Location of camera by making sure it is located for optimal view and ability to run wiring. Drill A ¾ inch hole.
2. Follow the wiring Diagram. Route the wire connector wire from the rear to the front where you routed the monitor end of the wire. Connect the Video jack wire together. Reconnect your battery and verify when the car is put in reverse, the monitor gives you an Image from the camera.
3. Adjusting The monitor settings. Push menu button until you reach desired option, use up and down buttons to adjust. Menu will time out after you are done.

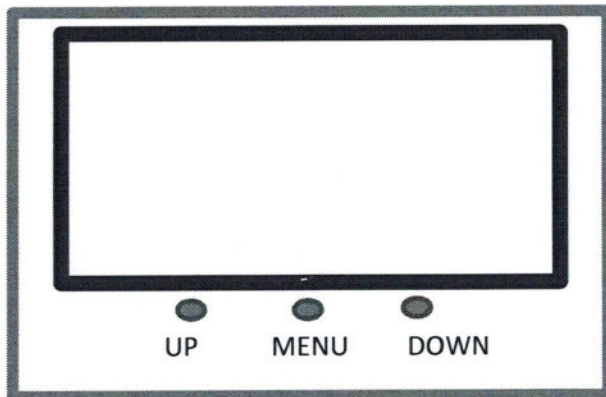

If you have any issues with Image quality due to interference please contact us for part #IT-MIR-NS

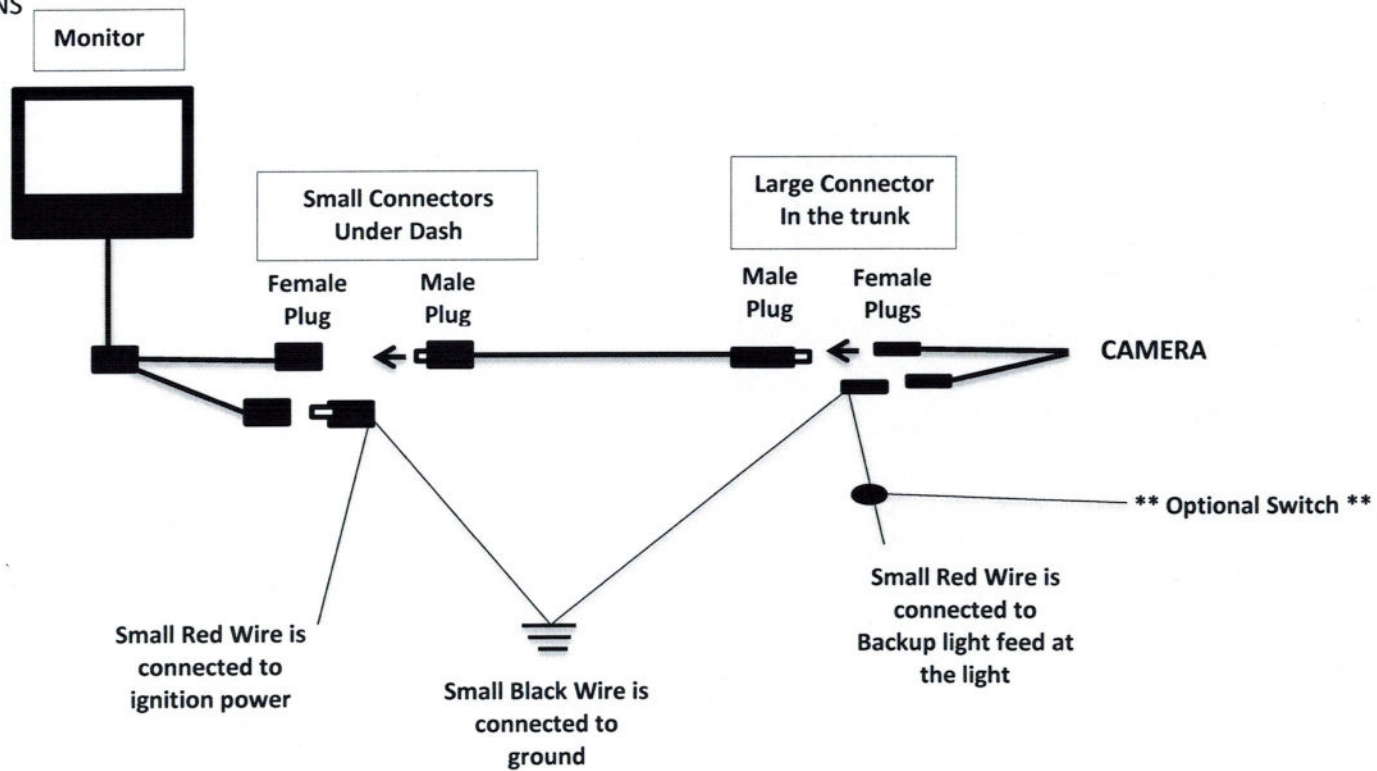

IT-MON Mounting and cutout

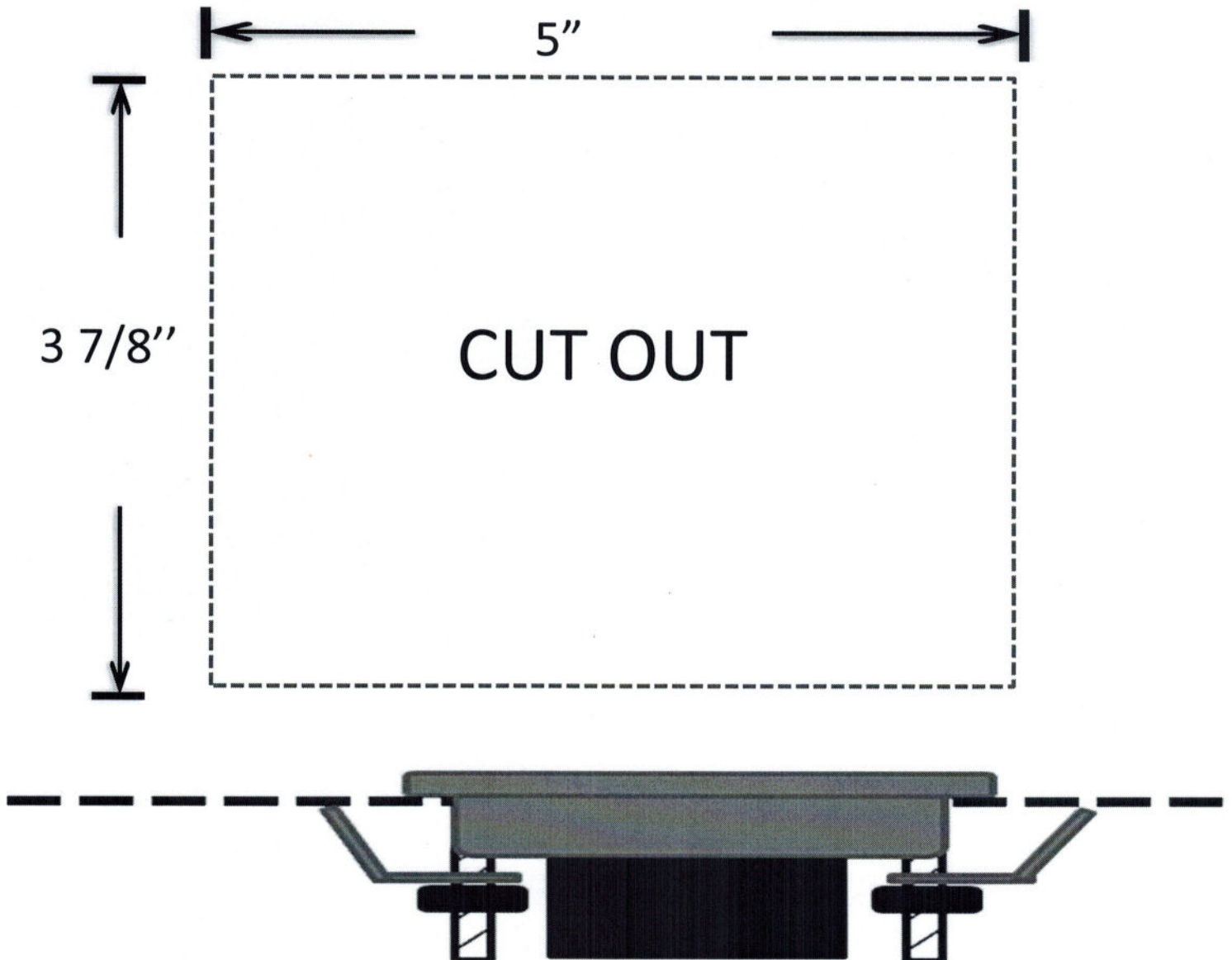

Mounting. Once the hole is cut insert the switch panel. Then use the L shaped brackets to grab the back of the upholstery and tighten the nuts so the L bracket just starts to bend.