

1. **Determine the Location** for the switches in your door panel or console. Make sure you have proper depth behind them.

2. **Cut Switch Holes** using the template/ dimensions **carefully** mark and cut holes.

3. **Mounting** once the hole is cut insert the switch panel. Then use the L shaped brackets to grab the back of the upholstery and tighten the nuts so the L bracket just start to bend.

4. **Do the Wiring.** The polarity reversing module can be located in the kick panels, under the dash or in the doors. In the door makes for the least number of wires going in-and-out of the door (2 wires "in" for console mounting + 2 crossover wires for in driver door mounting, not counting additional remote control or other switches), but the polarity reversing module must be protected from moisture. Always ground to a good chassis ground, not inside the door. Complete the wiring per the diagrams on the reverse side. The switch and frame will be attached to the panel, so leave ample wire to allow panel removal.

5. **Reconnect the main power and test your wiring.** For switches not oriented correctly for UP/DOWN, reverse either the yellow wire leads or the orientation of the switch in the panel.

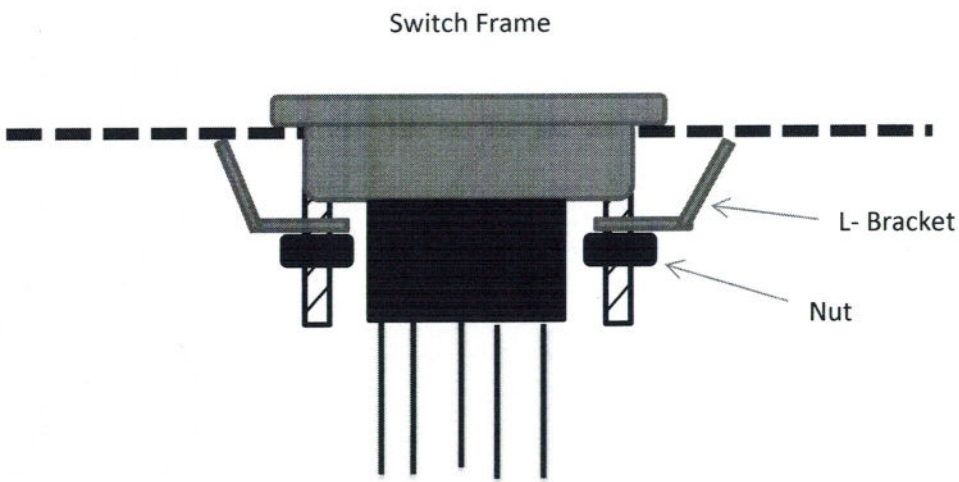

2 Switch Dimpled Power

#PW-5D

Window Switch Kit

Illuminated Double Billet switches and frame with lead wires and 2 polarity reversing modules. Adapt directly for use with (+) output remote controls – no additional relays needed.

DISCONNECT MAIN POWER AT THE BATTERY
BEFORE DOING ANY WIRING!

Switch Panel Template

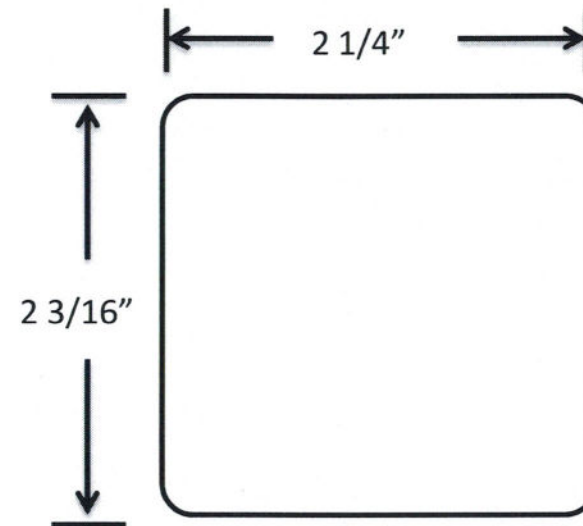

Doing electrical work, but you just aren't quite sure of yourself? Pick up a copy of our Basic Automotive Electricity Book. This fact filled book walks you through electricity from the basics to a complete automotive circuit diagram. It's a small price to pay for solving electrical headaches!

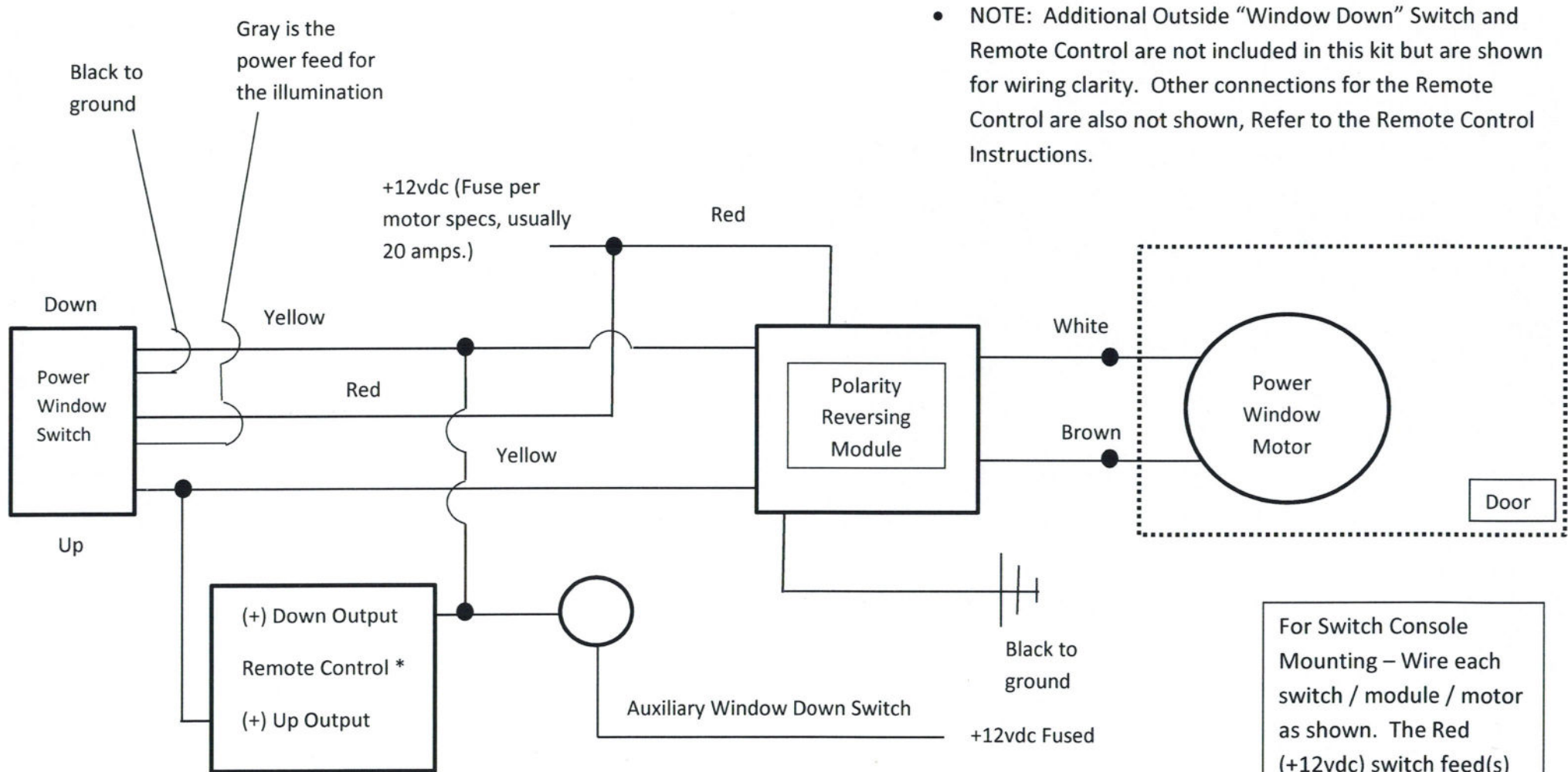

- NOTE: Additional Outside "Window Down" Switch and Remote Control are not included in this kit but are shown for wiring clarity. Other connections for the Remote Control are also not shown, Refer to the Remote Control Instructions.

For Switch Console Mounting – Wire each switch / module / motor as shown. The Red (+12vdc) switch feed(s) can be tapped off an alternate source as is convenient.

If you are mounting both switches in the driver door – Wire the driver door switch/module/motor as shown above. The Red (+12vdc) switch feed(s) can be tied together from the same source. The yellow switch wire leads off of the second (passenger door) switch must exit the driver door, crossover to and enter the passenger door and connect to the passenger door module/motor as shown.